

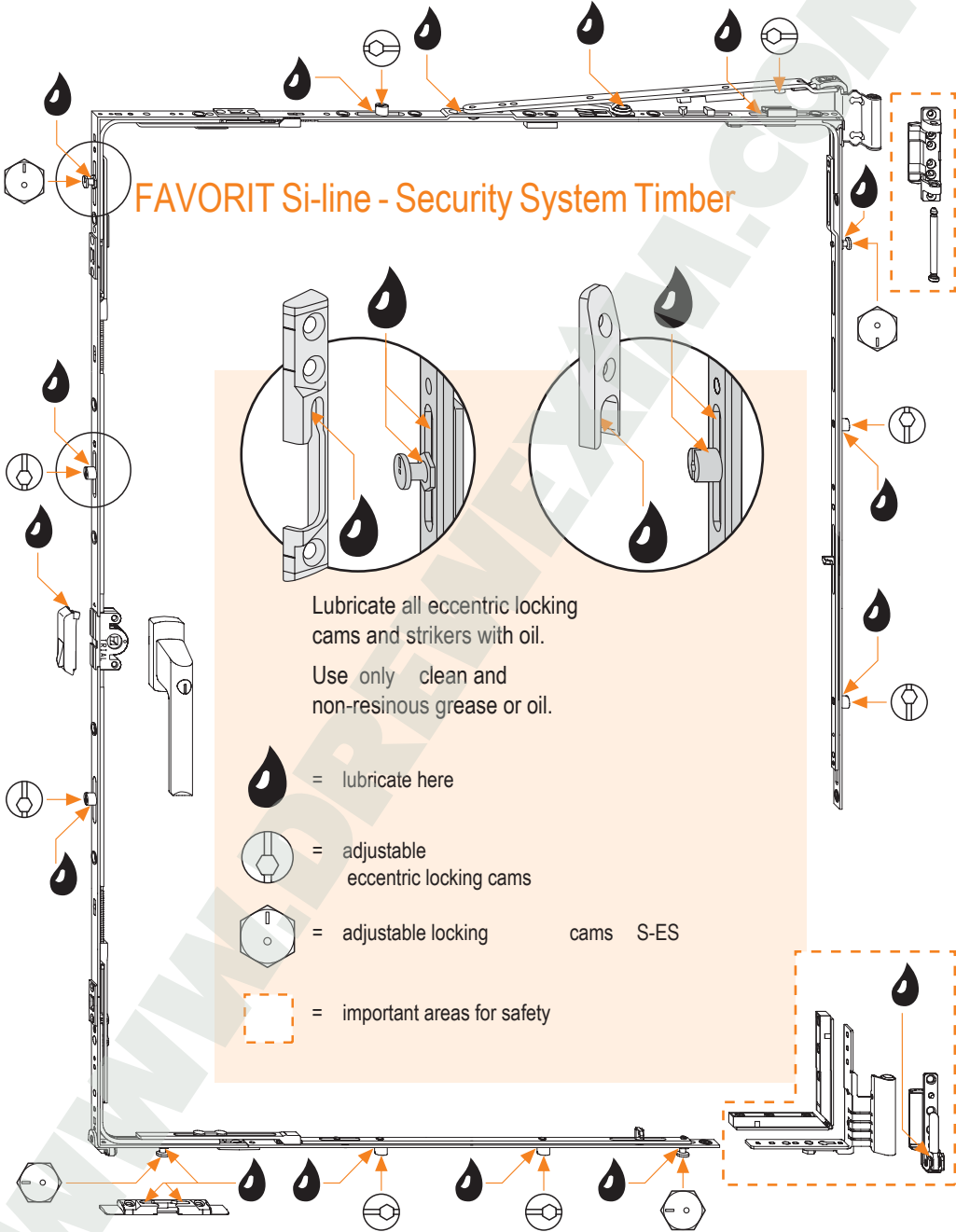



# Maintenance Instructions



# FAVORIT Si-line Security System Timber Arched-Head Window



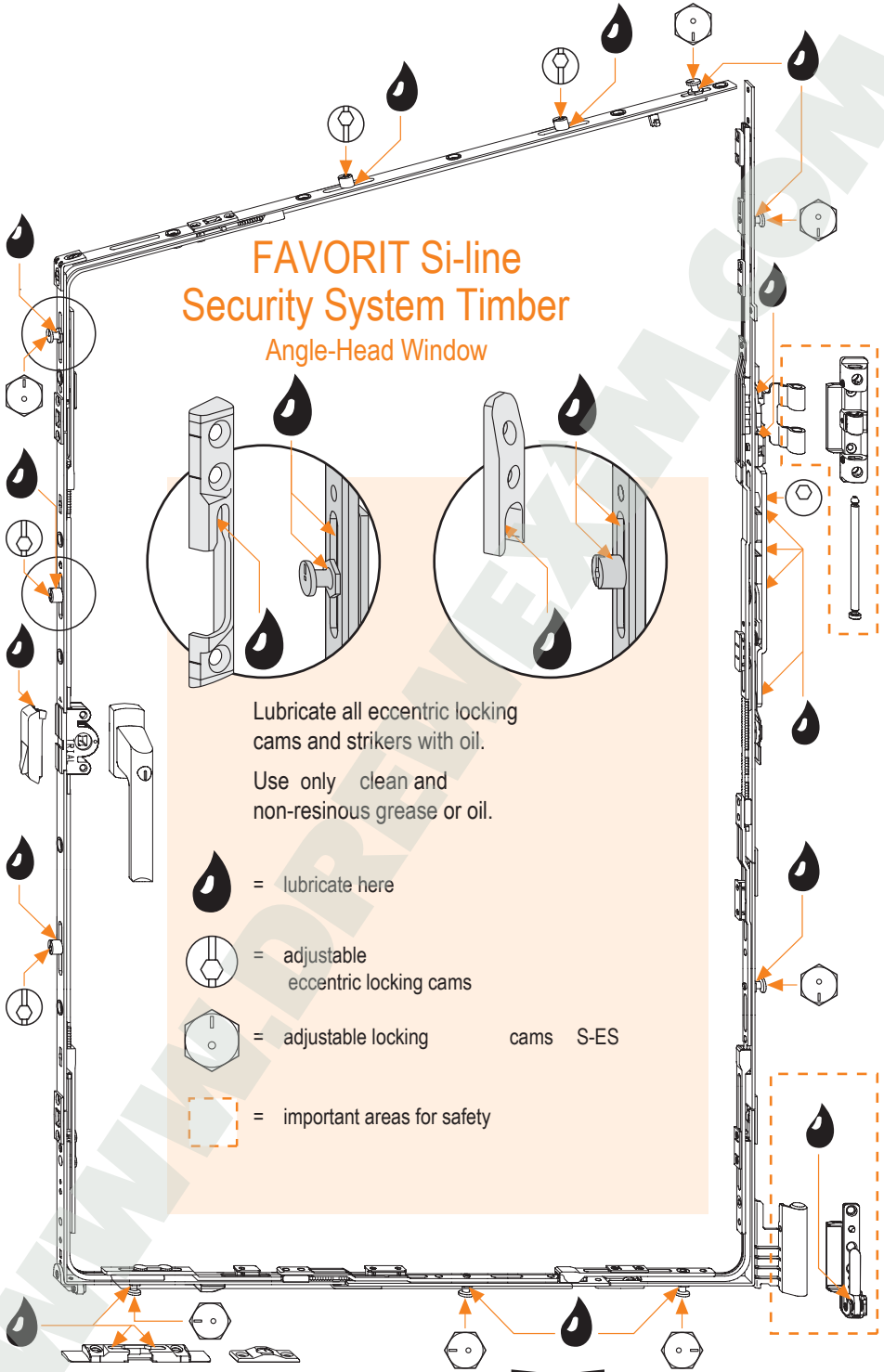

Lubricate all eccentric locking cams and strikers with oil.  
Use only clean and non-resinous grease or oil.

-  = lubricate here
-  = adjustable eccentric locking cams
-  = adjustable locking cams S-ES
-  = important areas for safety

# FAVORIT Si-line Security System Timber Angle-Head Window



Lubricate all eccentric locking  
cams and strikers with oil.  
Use only clean and  
non-resinous grease or oil.

-  = lubricate here
-  = adjustable eccentric locking cams
-  = adjustable locking cams S-ES
-  = important areas for safety

# Hanging a Tilt and Turn Window\*

## 1. Hanging sash onto bottom hinge

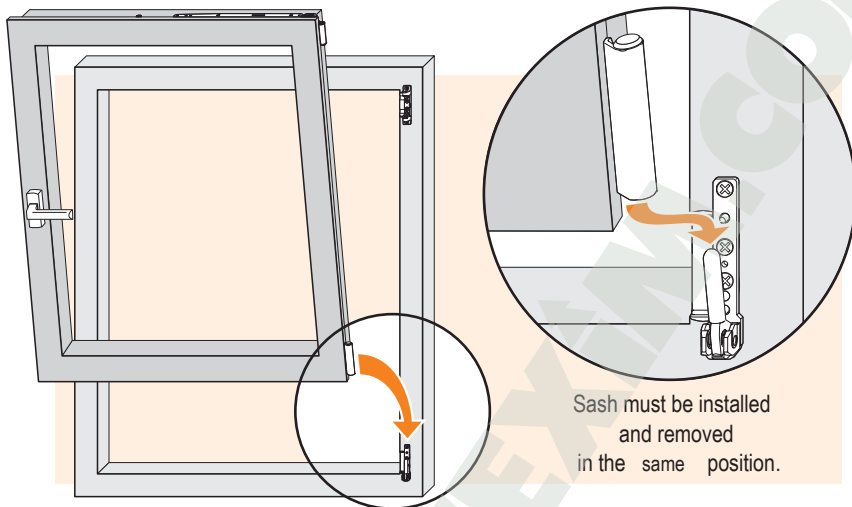

## 2. Connection to top hinge with built-in friction

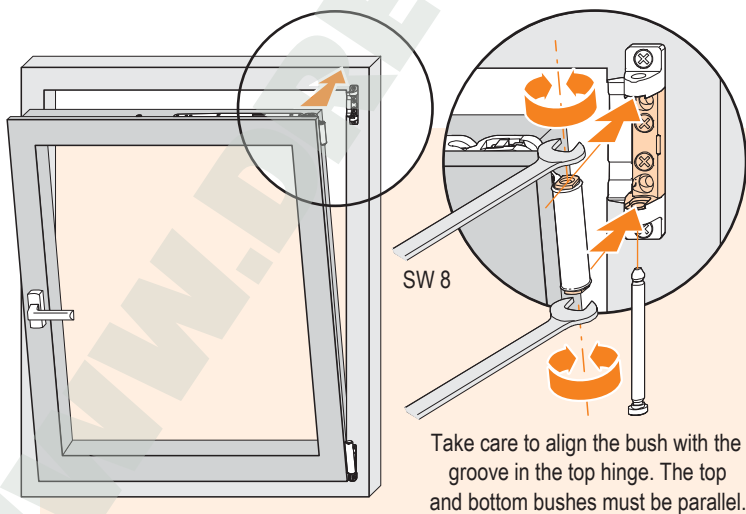

# Hanging a Side Hung Window\* with concealed centre lock

with concealed centre lock

1. Hanging sash onto bottom hinge

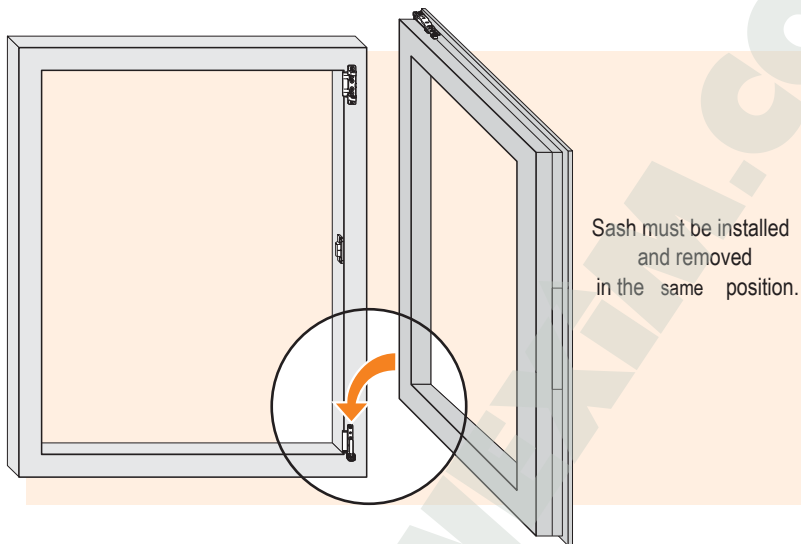

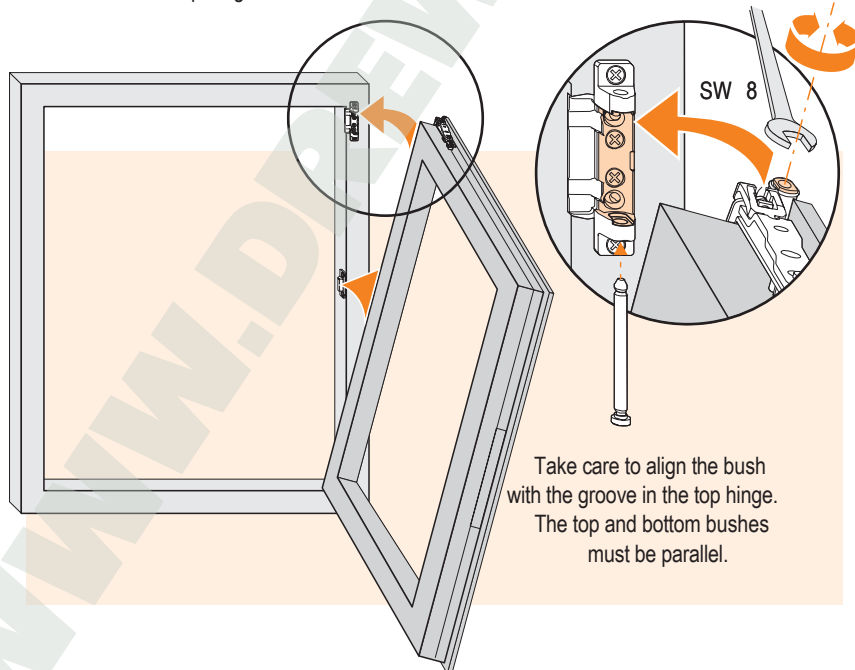

2. Connection to top hinge with built-in friction



## Special Notes:

Your windows are fitted with high quality components from SIEGENIA-AUBI. To ensure their smooth and trouble free operation you must carry out the following maintenance on them at least once a year:

1. Lubricate or oil all moving parts and locking points (  ).
2. Use only clean and non-resinous grease or oil.
3. Check all important security components (  ) for  tness and wear. If necessary tighten fixing screws and replace defective parts.
4. If these parts are not fitted with cover caps on your window, please check whether the top hinge pin is pushed up fully in the hinge.
5. Only clean your windows with a mild, neutral pH, diluted detergent. Never use aggressive, acid based detergents or scouring powder because they can damage the protective surface of your hardware.

To maintain the surface quality we recommend the following preventive measures:

6. After cleaning the hardware surface treat with a silicon and corrosion free (i.e. non-acidic) oil, e.g. sewing machine oil.

\*Warning, N.B. Malfunctions carry a risk of injury!

Do not continue to operate the window, but make it safe and have it repaired immediately; the following jobs should only be carried out by a specialist window company:

- the replacement of fittings
- the removal and replacement of sashes
- all adjustments of fittings - especially of hinges and stays

No sealants which are hardened by the effect of vinegar or acid, or those containing these substances, must be used on the window or in its immediate vicinity. Direct contact with the sealant or with its vapours could attack the surface of the hardware fittings.

If treating the surface of windows or doors - e.g. by painting or varnishing - all hardware components are to be excluded from this treatment and should also be protected against contamination.

These maintenance instructions are also valid for other fittings and window types that are not mentioned here.

Your Window specialist:



# Adjustments

The following adjustments should only be performed by an experienced window tradesman:

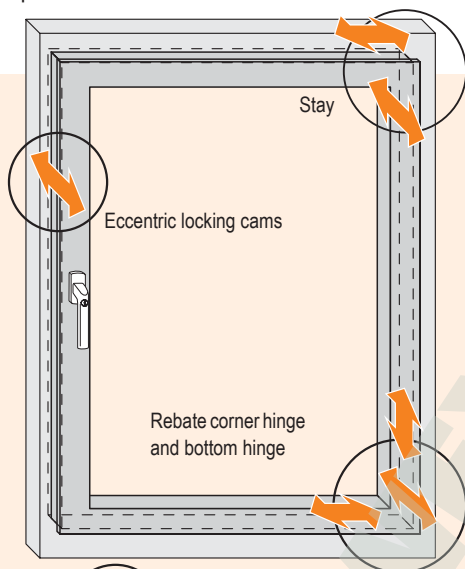

Important:  
Height and side adjustments may be limited, depending on the security level.

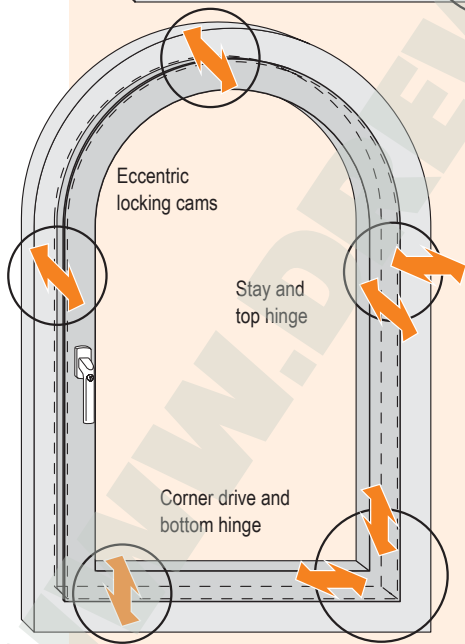

Run-up and tilt lock bearing

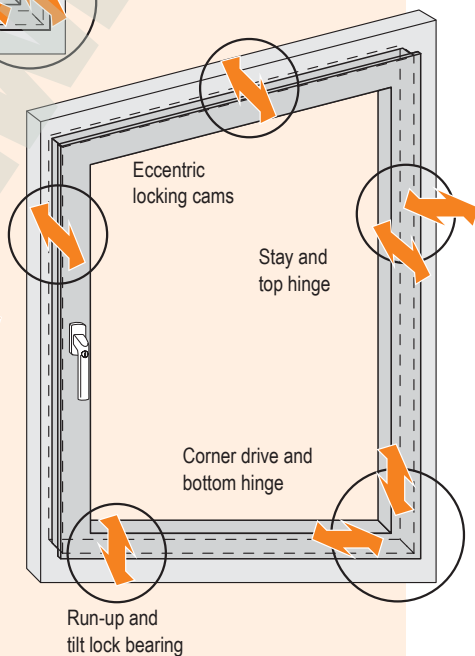

# Adjustable Parts

## Eccentric locking cams

Sash closing pressure adjustment

Adjustment

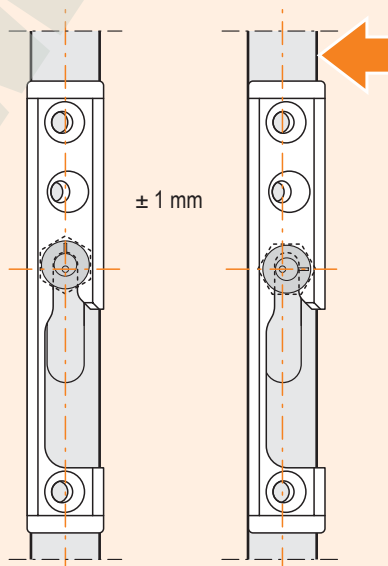
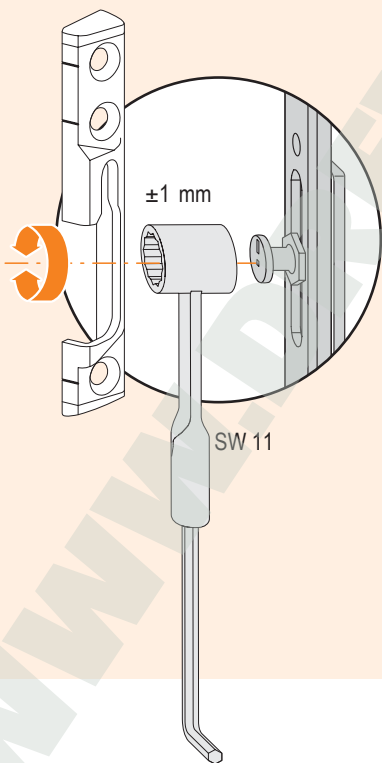
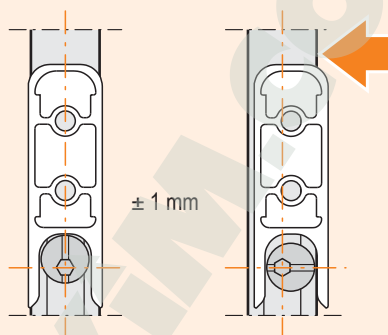
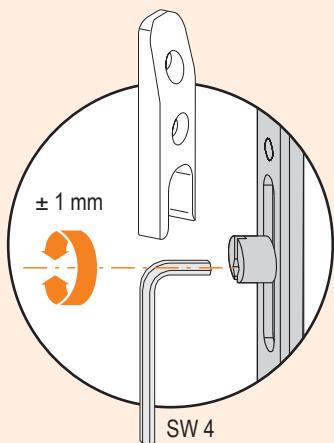

# Adjustable Parts

Stay 7

Side to side adjustment

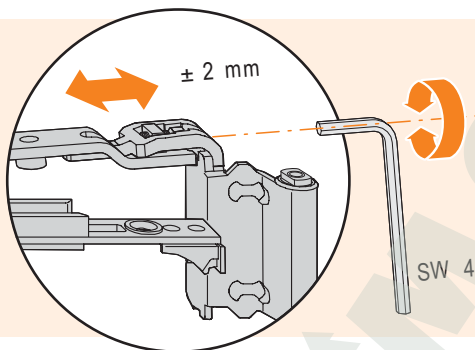

Stay 7

Closing pressure adjustment

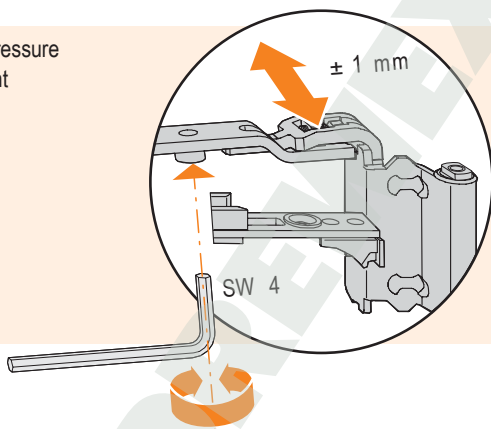

Stay RB

Closing pressure adjustment

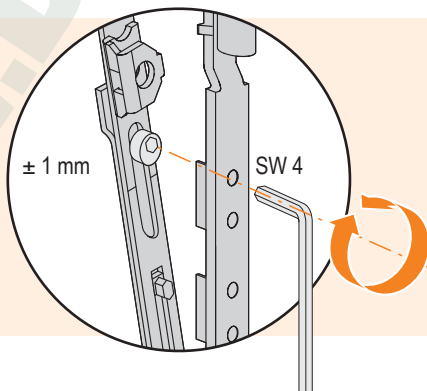

# Adjustable Parts

Corner drive BSU S-ES ...

Height adjustment

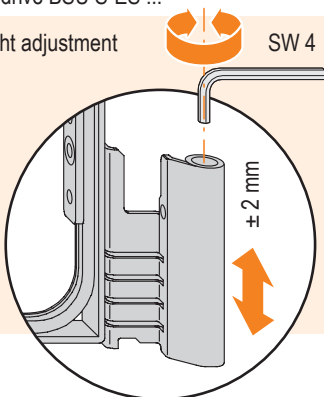

Top hinge RB

Side to side adjustment

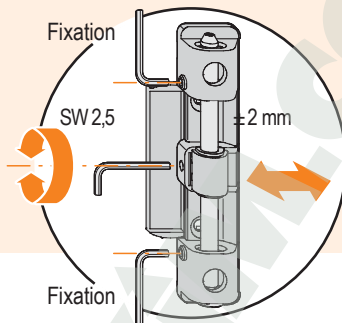

Rebate corner hinge

Closing pressure adjustment

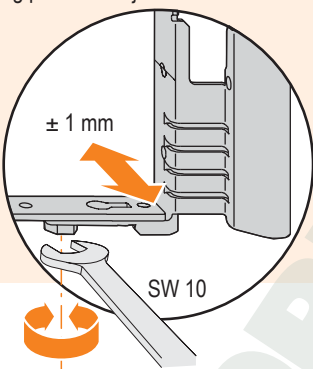

Height adjustment

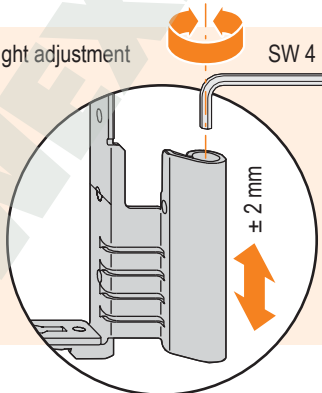

Run-up

Height adjustment

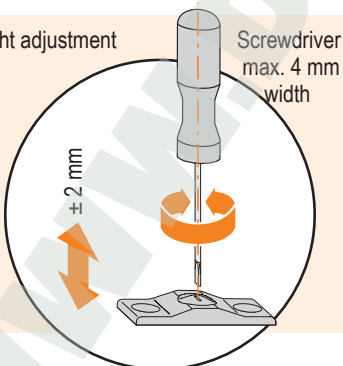

Bottom hinge

Side to side adjustment

